

PROTECTION CIRCUITS FOR QUAD AND OCTAL LOW SIDE POWER DRIVERS

by Wayne Austin

Overview

Normally, the defined requirements for a Quad or Octal Driver are very much affected by the type of protection circuits used on the chip. Fault protection for an open or shorted load is an inter-active function, making it important in the decision process of specifying the proper IC for an application. The various types of on-chip features may include protection for over-current, over-voltage and over-temperature. The response action to a fault condition may be either limiting or shutdown. Shutdown methods may include hysteresis and may require a logic reset. On-chip clamp diodes provide current steering to an external zener diode clamp as over-voltage protection from inductive switching pulses. Internal Zener diodes are also used to limit the output voltage on the output driver of the IC. In addition, fault detection is available with diagnostic feedback, including serial bus (SPI) control. All of the protection features noted are represented in the Table 1 listing of Quad and Octal Low Side Drivers:

TABLE 1. QUAD & OCTAL LOW SIDE POWER DRIVERS

TYPE	DESCRIPTION	KEY FEATURES
CA3242	Quad Gated Inverting Power Dr.	Over-Current Latch-Off, Fast Fault Shut-Down, Output Protection Diodes
CA3262	Quad Gated Inverting Power Dr.	Over-Current Limiting, Over-Temperature Limiting, Output Protection Diodes
CA3262A	Quad Gated Inverting Power Dr.	Same as CA3262 plus +125°C Max. T _A Range.
CA3272 and CA3272A	Quad Gated Inverting Power Dr. with Fault Mode Diag. Flag Output	Over-Current and Temp. Limiting, Fault Flag Output, +125°C Max. T _A Range. CA3272A has improved Fault Flag Output Drive Capability.
CA3282	Octal Driver with SPI Logic Control	Over-Current and Over-Voltage Fault Mode Protection with Fault Mode Feedback/Control with -40°C to +125°C Max. T _A Range.
CA3292A	Quad Gated Inverting Power Dr. with Fault Mode Diag. Flag Output	Similar to CA3272A with added Internal Over-Voltage Output Clamp.
HIP0080 and HIP0081	1A and 2A Quad Gated Inverting Power Drs. with Multi-mode Diag. Feedback	Over-Current (Latch-Off), Over-Temperature (Gates-Off), Open Load and Output Ground Short Detection, Over-Voltage Internal Output Clamp Diodes, Fault Mode Feedback/Control and -40°C to +125°C Max. T _A Range.

While the CA3282 Octal Driver is quite different from the quad drivers, it is included here because it is used in similar applications. The CA3282, HIP0080 and HIP0081 feature Power BiMOS with MOSFET Output Drivers for higher current and voltage capability. Because of the additional dissipation associated with these drivers, the CA3282 and HIP0081 are provided in a 15 pin SIP power package. The other Quad Drivers are available in the 16 pin DIP and/or 28 lead PLCC packages which have special construction for improved heat dissipation. All of these Low Side Switches generally share a common characteristic of 5V input CMOS or TTL logic level control.

The Quad and Octal Power Drivers include a wide variation of choice in selecting a device type. The available types are listed in TABLE 1 which also highlights the key parameters for most applications. By-type, the protection features of the Quad and Octal Drivers are listed in the table and are explained in the following detail of this IC Application Note to assist the user in making an intelligent device selection for the application of interest.

CA3242 Quad Power Driver

In normal use, the supply voltage is applied through a load to an NPN open collector output of the CA3242 quad driver. The functional block diagram is shown in Figure 1. The maximum current rating of 1A does not distinguish between average and peak. Each output is independently protected and latches "OFF" when the load current exceeds the latch-off threshold in the "ON" state. The CA3242E feature of short circuit protection is a responsive high-speed shutdown of the output drive to a shorted load. Under worse-case shorted load conditions, the supply voltage is applied direct to the output device. The latch-off threshold is typically 1.3V (I_{SC}R_{ON}), where R_{ON} is the saturated "ON" resistance of the output. The CA3242 latches "OFF" at a typical short circuit current of 1.2A with 25μs nominal delay. The ENABLE or the IN pin of the latch-tripped channel must be toggled to reset the latch.

To better understand the mechanism of protection when the CA3242 is subjected to a shorting condition, Figure 2 illustrates that part of the Figure 1 noted as the "PROT" functional block. When an over-load current is applied to an output driver, the V_{SAT} increases to a threshold level set in a

Application Note 9201

TABLE 2. QUAD AND OCTAL DRIVER FEATURES

	CA3242	CA3262	CA3262A	CA3272 CA3272A	CA3292A	HIP0080	HIP0081	CA3282 (OCTAL DR.)
Max. Output Voltage, No Load	50V	60V	60V	60V	32V Typ. (Clamp)	36V Typ. (Clamp)	80V Typ. (Clamp)	32V Typ. (Clamp)
Max. Output Load Current	0.6A	0.7A	0.7A	0.6A	0.6A	1A	2A	1A
Max. V_{SAT} Output Voltage Max. R_{ON} Output Resistance	0.8V at 0.6A	0.6V at 0.6A	0.5V at 0.6A	0.4V at 0.5A	0.4V at 0.5A	1.0Ω at 0.5A	0.5Ω at 1A	1Ω at 0.5A
Max. Load Switching Voltage, $V_{CE(SUS)}$ or V_{CLAMP} Limited	35V	40V	40V	40V	28V	27V	73V	30V
Typical Output Current Limiting and/or Shutdown Protection	1.4A (Latches Off)	1.6A	1.3A	1.2A	1.2A	1.8A (Latches Off)	3.5A (Latches Off)	1.5A (Latches Off)
Output Thermal Limiting and/or Shutdown Protection (Temp. T_J)	None	155°C (Limits)	155°C (Limits)	165°C (15°C hys.)	165°C (15°C hys.)	150°C (15°C hys.)	150°C (15°C hys.)	None
Over-Voltage Protection	Current Steering Clamp Diode			None	Zener Diode Feedback Clamp			
Fault Diagnostics	No			Fault Flag		Fault Mode Flag and Feedback		
Temp. Range, -40°C to ___°C	105°C	85°C	125°C					
Packages: 16 DIP Pwr WEB (PC Bd, θ_{JA}) 28 PLCC Pwr WEB (PC Bd, θ_{JA}) 15 SIP (Tab H.S., θ_{JC})	40°C/W	40°C/W	40°C/W	30°C/W	30°C/W	30°C/W	30°C/W	30°C/W
							3°C/W	3°C/W

comparator circuit. The comparator outputs a switching signal to the protection latch and the input drive is "latched-off". The input may be reset with an INPUT or ENABLE toggle, or by and ON-OFF toggle of the power supply to the control circuits.

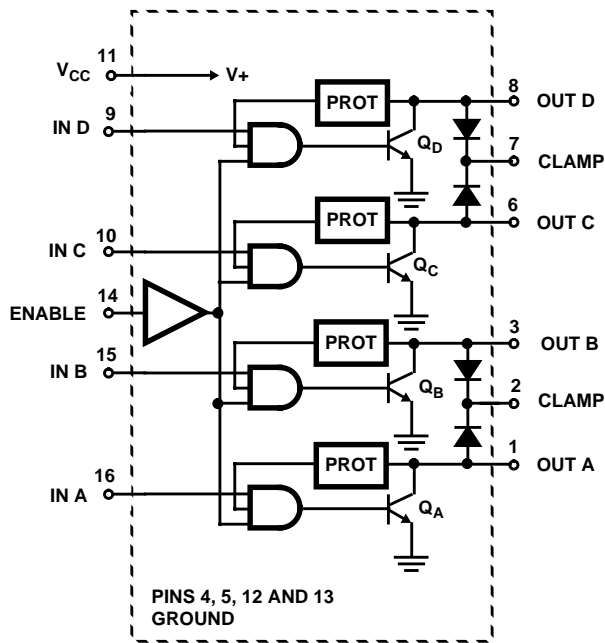

FIGURE 1. CA3242 FUNCTIONAL BLOCK DIAGRAM

Proper application will protect the CA3242E during turn-off under shorted load conditions. Observations of wide ranging conditions have been done to test the shutdown behavior and has revealed several pitfalls that should be addressed to assure safe shutdown. One should be aware that a forced short circuit test condition may be considerably more severe than a normal application shorted load. In either case, two problems arise that affect the severity of the overload during shutdown. These are:

1. A shorted load is inductive and causes the generation of voltage spikes, exposing the output device to at least 2 times the value of the V_+ supply voltage.
2. Lack of bypassing can provoke severe oscillations during the delay period before shutdown is complete. This is typically less than 25μs.

The result of this oscillation with an inductive load is to alternately stress the output device in both a forward and reverse direction at rates as high as 1mHz, lasting until shutdown occurs. This problem is compounded in some applications when 2 or more devices are used in parallel to increase drive output. In this case, a short may now draw twice the current of one driver which, in turn, results in almost twice the unclamped voltage spike developed across each output transistor.

To suppress oscillations during shutdown requires some attention to the use of adequate bypassing of both the +5V V_{CC} supply and the battery or output supply voltage. Bypassing the output supply will minimize both the transient oscillations and the voltage spike effects of lead inductance.

Application Note 9201

Then, the shorted output is stressed in the forward bias mode with the shorted current determined by voltage source, duration of short, line resistance and the resistance of the saturated output. In a practical application, the load and any potential short may occur in a remote location. As such, bypassing the output supply may not be practical. Bypassing the +5V supply with a 0.1 μ F capacitor closely wired to pins 11 and 12 of the CA3242E constitutes adequate bypassing of the +5V supply.

Because voltage spikes are normal to the application, a 30V zener "clamp" diode is needed to limit the device output voltage spikes to less than the maximum rating of 35V. The zener clamp diode protection should be closely wired to pins of the output divide in order to avoid any delay in the voltage clamping action. Alternatively, the on-chip diodes may be used in a free wheeling mode by connecting the CLAMP pins to the supply voltage if it does not exceed 30V during transients. Zener diode clamp protection is preferred over the power supply clamp option, primarily because the power supply may be subject to large transient changes.

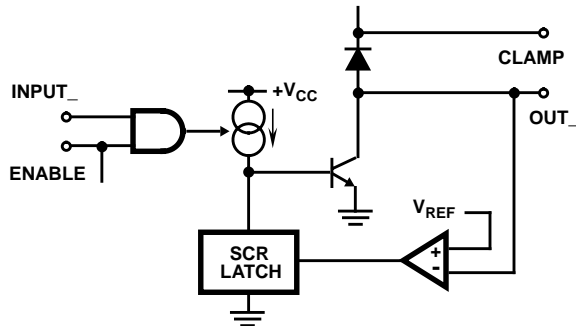

FIGURE 2. CA3242 FUNCTIONAL DIAGRAM FOR EACH OUTPUT CHANNEL SHOWN WITH PROTECTION CIRCUIT

CA3262 and CA3262A Quad Power Drivers

The CA3262 is a quad-gated inverting low-side driver capable of switching 700mA load currents (at +25°C) in each output without interaction between the outputs. Shown in Figure 3, each output is independently protected with over-current limiting and over temperature limiting features. If an output load is shorted, the remaining three outputs function normally unless the junction temperature of their output device exceeds the over temperature limiting threshold of +155°C (typical). Current limiting prevents the output current from exceeding a value determined by the design (1.2A typical), independent of the load condition. The power dissipation of the shorted output driver is equal to the product of the limiting value of current and the applied output collector voltage. If this value causes the junction temperature to exceed +155°C (typical), the base drive to the output transistor, and thereby its collector current, is reduced until the resulting power dissipation is equal to that value which maintains the junction temperature at the thermal limit value. The current which flows in the output transistor in a short circuit mode is therefore a function of the ambient temperature, the thermal resistance of the package in the application, the total power dissipated in the package. If the short is removed, normal operation resumes automatically.

In order to clamp high voltage pulses which may be generated by switching inductive energy in the load circuit, zener diodes with a value not greater than 30V should be connected to the CLAMP pins. On-chip diodes are connected from each output to one of the two CLAMP pins and are intended for use as steering diodes to provide a path for the clamped pulse current to a CLAMP pin; allowing the use of one zener diode to clamp all outputs. Alternatively, the on-chip diodes may be used in a free-wheeling mode by connecting the CLAMP pins to the supply voltage if it does not exceed 30V during transients. Zener diode clamp protection is preferred over the power supply clamp option, primarily because the power supply voltage may be subject to large transient changes. Note that the rate of change of the output current during switching is very fast. Therefore, even small values of inductance (such as the inductance of several meters of wire) in the load circuit can generate voltage spikes of considerable amplitude on the output terminals and may require clamping to prevent damage.

The CA3262A is a lower V_{SAT} version of the CA3262 and is rated for +125°C ambient temperature applications. The CA3262 is limited to about +100°C (data sheet rating at +85°C) ambient temperatures. Otherwise, the protection features described here apply to both versions. Figure 3 shows a functional block diagram for the CA3262 and CA3262A. Each type has independent current limiting and thermal limiting protection for each output driver. The maximum current rating of each output is typically greater than 1.2A. However, this is not a users choice rating, the current limiting may range from 0.7A to as high as 2A.

Typical applications of the CA3242 and CA3262 quad drivers with the recommended method for use of the current steering diodes is shown in the circuit of Figure 4. Where inductive loads are not used, the protective diodes need not be externally connected. However, the user should be alert to the potential for stored energy in long wire connections to the load circuits.

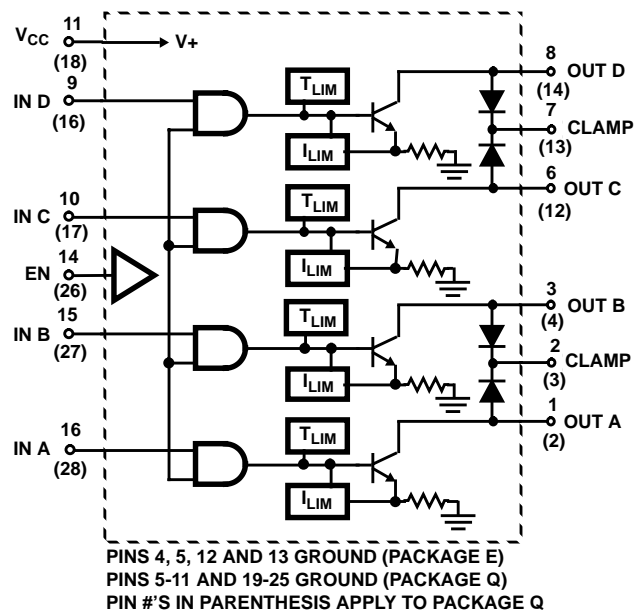

FIGURE 3. CA3262 AND CA3262A FUNCTIONAL BLOCK DIAGRAM

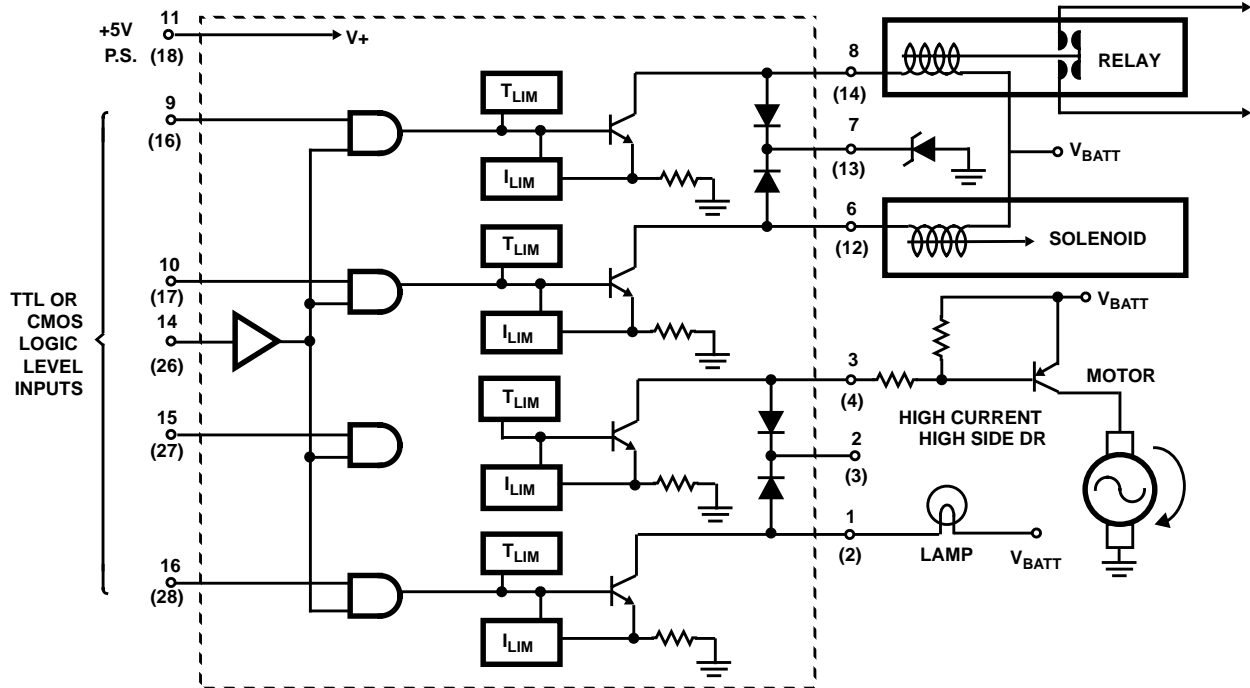

FIGURE 4. TYPICAL APPLICATION CIRCUIT FOR THE CA3262 AND CA3262A QUAD POWER DRIVERS WITH PROTECTION DIODES EXTERNALLY CONNECTED TO A ZENER CLAMP DIODE FOR INDUCTIVE LOAD PROTECTION.

The CA3262 and CA3262A will typically survive when shorted if the output supply voltage is less than 18V. This potential for failure is flagged in the data sheet as a note under the Electrical Characteristics table. It takes a few milliseconds to shutdown when the output is short circuited. During shutdown the dissipation may be excessive and is primarily determined by I_{SC} which is the limiting current. The short-circuit current will be limited but the voltage that the shorted output sees may approach V_{SUPPLY} . Not considering transient effects, the worst case dissipation would be $P_D = (V_{SUPPLY}) \times (I_{SC})$. Normally, a shorted solenoid or relay will have a few ohms of impedance which should prevent catastrophic IC failure in 12V automotive applications. A typical value for I_{SC} is 1.3A. R_{ON} is the saturated collector resistance of the output transistor with a typical value of 1 Ω . V_{SUPPLY} is normally 9V to 16V in automotive applications. The thermal shutdown could be made faster but the circuit would not be able to effectively drive lamps which have a very low resistance in a cold start-up. Lamp drive capability is a common application use for the CA3262 and CA3262A.

CA3272 and CA3292 Quad Power Drivers with Fault Mode Flag

The CA3272 and CA3292 are quad-gated inverting low-side power drivers with a fault diagnostic flag output. They are rated for +125°C ambient temperature applications and have current limiting and thermal shutdown. As shown in Figure 5, they differ from the CA3262A by not having output clamp diodes but do have the diagnostic short-circuit flag outputs. Each output driver is capable of switching 400mA load currents at +125°C ambient without interaction between the outputs. Current limiting functions in the same manner as the CA3262 with a typical limit value of 1.2A. The current limiting range is set for 0.6A to 1.6A. While the thermal shut-

down characteristics differ from the CA3262 by having hysteresis, the same precaution applies for potential damage from high transient dissipation during thermal shutdown. The CA3272Q, CA3272AQ and CA3292AQ Quad Driver are provided in the 28 pin web-leadframe PLCC package. This package has slightly lower thermal resistance than the 16 lead DIP package with a web leadframe.

The FAULT DETECTOR circuit of the CA3272, CA3272A and CA3292A is shown in Figure 6 as an equivalent logic block diagram. Channel A is one of 4 power switching functions displayed in the diagram. Transistor Q_A is the protected power transistor switch that drives the "OUT A" terminal. The FAULT DETECTOR block illustrates the logic functions associated with FAULT DETECTION. The ENABLE input is common to each of the 4 power switches and also disables the FAULT output when it is low. From the "IN A" input to the "OUT A" output, the switch condition is inverting (NAND). When IN is high, OUT is low. The FAULT DETECTOR senses the IN and OUT states and switches Q_F "ON" if a fault is detected. Transistor Q_F activates a sink current source to pull-down the FAULT pin to a 0 (low) state when the fault is detected. Both shorted and open load conditions are detected.

The CA3292A is equivalent to the CA3272A except that it has internal clamp diodes on the outputs to handle inductive switching pulses from the output load. The CA3272A and CA3292A have significantly higher I_{OL} FAULT output drive than the CA3272. Expanded functional block diagram detail of the fault logic is similar to that of the CA3272 as shown in Figure 6. The structure of each CA3292A output, shown in Figure 6B, includes a zener diode from collector-to-base of the output transistor. This is a different form of protection than the CA3242 or CA3262 which have current steering clamp diodes on each output, paired to one of two "CLAMP"

Application Note 9201

output pins. The CA3292A output transistor will turn-on at the clamp voltage threshold which is typically 32V and the output transistor will dump the pulse energy through the output driver to ground.

Each of the outputs are independently protected with over-current limiting and over-temperature shutdown with thermal hysteresis. If an output is shorted, the remaining outputs function normally unless the temperature rise of the other output devices can be made to exceed their shutdown temperature of +165°C (typical). When the junction temperature of a driver exceeds the +165°C thermal shutdown value, that output is turned off. When an output is shutdown, the resulting decrease in power dissipation allows the junction temperature to decrease. When the junction temperature decreases by approximately 15°C, the output is turned on. The output will continue to turn on and off for as long as the shorted condition exists or until shutdown by the input logic. The resulting frequency and duty cycle of the output current flow is determined by the ambient temperature, the thermal resistance of the package in the application, the total power dissipation in the package. Since each output is independently protected, the frequency and duty cycle of the current flow into multiple shorted outputs will not be related in time. Long lead lengths in the load circuit may lead to oscillatory behavior if more than two output loads are shorted.

A diagnostic flag indicates when an output is shorted. This information can be used as input to a microprocessor or dedicated logic circuit to provide a fast switch-off when a short occurs and also to determine by sequence action, which output is shorted. A fault condition in any output load will cause the FAULT output to switch to a logic "low". Added detail of the fault logic is shown in Figure 6A. Since a fault condition will be indicated during switching, use of an appropriate size capacitor to filter the FAULT output is recommended (see data sheet). This will prevent the FAULT output voltage from reaching a logic level "0" within the maximum switching time. The FAULT detection circuitry compares the state of the input and the state of the output. The output is considered to be in a high state if the voltage exceeds the typical FAULT threshold reference voltage, V_{THD} of 4V. If the output voltage is less

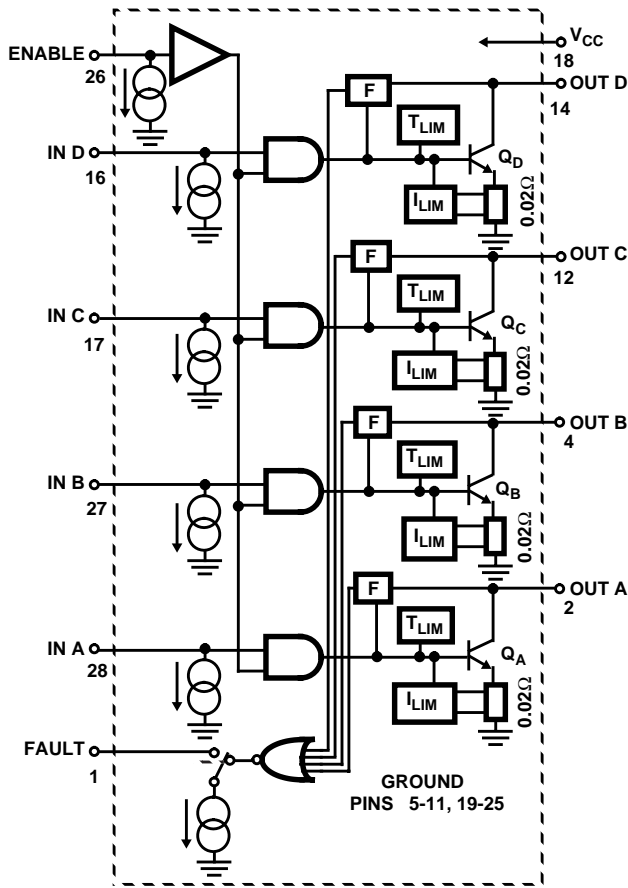

FIGURE 5. CA3272 AND CA3272A FUNCTIONAL BLOCK DIAGRAM

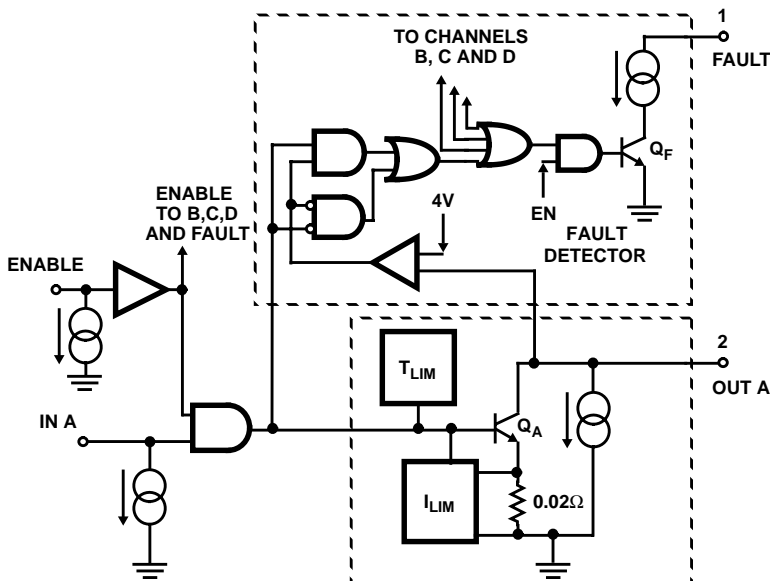

FIGURE 6A. FAULT DETECTOR SHOWN WITH THE CA3272 AND CA3272A OUTPUT STAGE

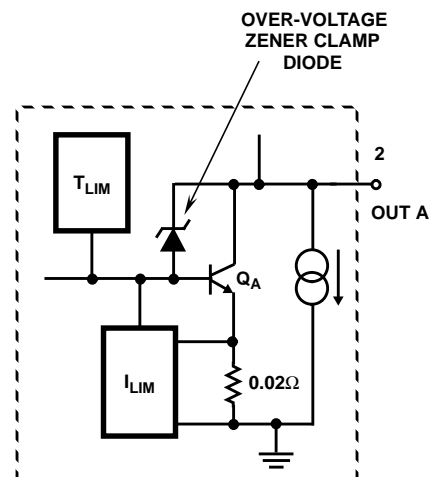

FIGURE 6B. CA3292A OUTPUT STAGE WITH CLAMP DIODE

FIGURE 6. FAULT DETECTION FUNCTIONAL BLOCK DIAGRAM OF THE CA3272, CA3272A AND CA3292A

than V_{THD} , the output is considered to be in a low state. For example, if the input is high and the output is less than V_{THD} , a normal "ON" condition exists and the FAULT output is high. If the input is high and the output is greater than V_{THD} , a shorted load condition is indicated and the FAULT output is low. When the input is low and the output is greater than V_{THD} , a normal "OFF" condition is indicated and the FAULT output is high. If the input is low and the output is less than V_{THD} , an open load condition exists and the FAULT output is low. The FAULT output is disabled when the ENABLE input logic level is low.

To detect an open load, each output has an internal low-level current sink which acts as a pull-down under open load fault conditions and is always active. The magnitude of this current plus any leakage associated with the output transistor will always be less than $100\mu A$. (The data sheet specification for I_{CEX} includes this internal low-level sink current). The output load resistance must be chosen such that the voltage at the output will not be less than V_{THD} when the I_{CEX} sink current flows through it under worst case conditions with minimum supply voltage. For example, assume a 6.5V minimum driver output supply voltage, a maximum FAULT threshold reference voltage of $V_{THD} = 5.5V$ and an output current sink of $I_{CEX} = 100\mu A$. Calculate the maximum load resistance that will not result in a FAULT output low state when the output is OFF.

$$R_{LOAD(max)} = [V_{SUPPLY (min)} - V_{THD (max)}] / I_{CEX (max)}$$

$$R_{LOAD(max)} = (6.5V - 5.5V) / 100\mu A = 10k\Omega$$

Since the CA3272 and CA3272A do not have on-chip diodes to clamp voltage spikes which may be generated during inductive switching of the load circuit, external zener diodes (30V or less) should be connected between the output terminal and ground. Only those outputs used to switch inductive loads require this protection. Note that since the rate of change of output current is very high, even small values of inductance can generate voltage spikes of considerable amplitude on the output terminals which may require clamping. External free-wheeling diodes returned to the supply voltage are generally not acceptable as inductive clamps if the supply voltage exceeds 30V during transients.

CA3282 Octal Power BiMOS Driver with SPI Bus

The CA3282 is a logic controlled Power Driver with a Serial Peripheral Interface (SPI). The chip is fabricated in a Power BiMOS process with high voltage and current drive capability. A functional block diagram is shown in Figure 5. There is an extensive amount of logic circuitry to provide individual diagnostic feedback; including which output may be shorted. Each of the open collector output drivers has individual protection for over-current and overvoltage; and, each output has separate output latch control. The current limiting of the CA3282 is set for a range of 1A to 2A (1A min.). In the normal ON state, each output driver is in a saturated low state. Comparators in the diagnostic circuit monitor the drain of the output drivers to determine if an out-of-saturation condition exists. If a comparator senses a voltage higher than the threshold trip level of 3V typical, the latch control circuit is reset (unlatched) and the respective output driver is shutdown. The on-chip current limiting protection is independent of the diagnostic feedback loop. If an over-current condition exists, the condition may be sustained unless the diagnostic circuit senses a fault condition. Open-load faults may be detected with a diagnostic check of the output in the off state. A $150\mu A$ typical internal current sink pull-down forces the output low when it would otherwise be high.

Maximum current ratings allow all eight outputs to be turned on to a level of 0.5A. This is allowed because the CA3282 chip is packaged in 15 pin SIP power package with $3^{\circ}C/W$ typical junction-to-case thermal resistance, allowing high dissipation capability in ambient temperatures up to $125^{\circ}C$. The CA3282 output driver structure consists of a MOSFET with a zener diode feedback from the drain to gate, forming an overvoltage clamp structure for protection from voltage spikes generated when switching inductive loads. The pulse energy is shunted to ground through the MOSFET output driver.

The CA3282 protection features support many application requirements. A typical application circuit is shown in Figure 8. Where inductive loads are used, no external diode is needed to shunt the load coil turn-off pulse. However, it is important to adhere to the maximum peak current ratings for currents that can flow in the output devices. The output drivers are turned-on by an internal zener feedback for over-

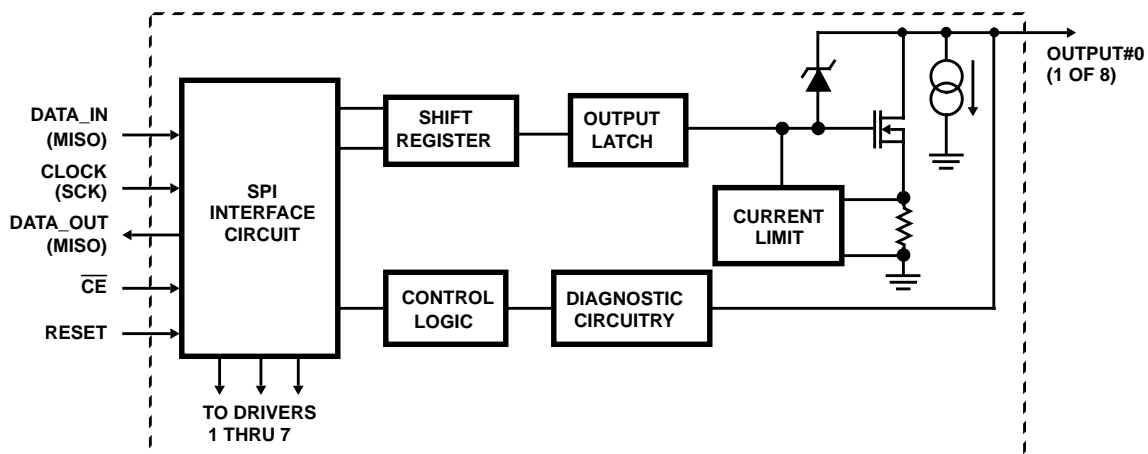

FIGURE 7. CA3282 BLOCK DIAGRAM FOR ONE OF EIGHT DRIVER STAGES

Application Note 9201

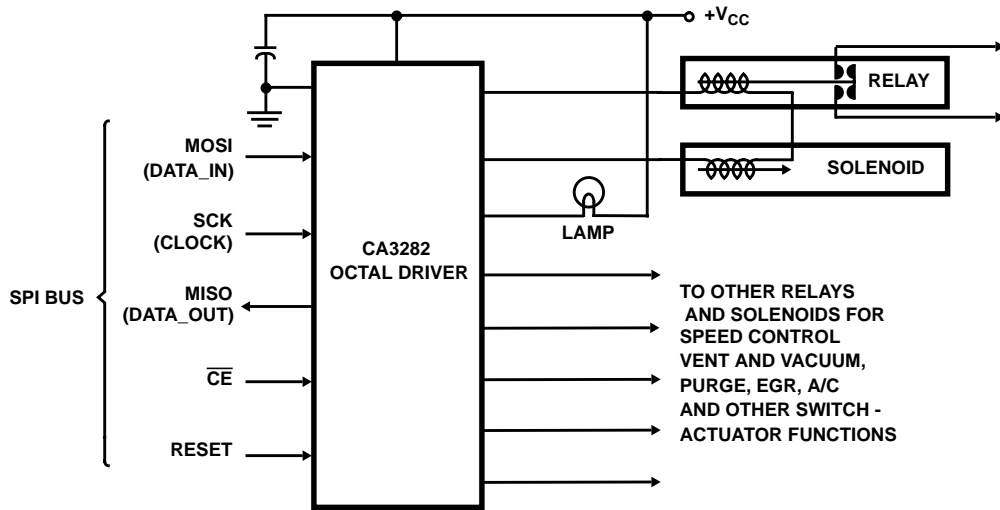
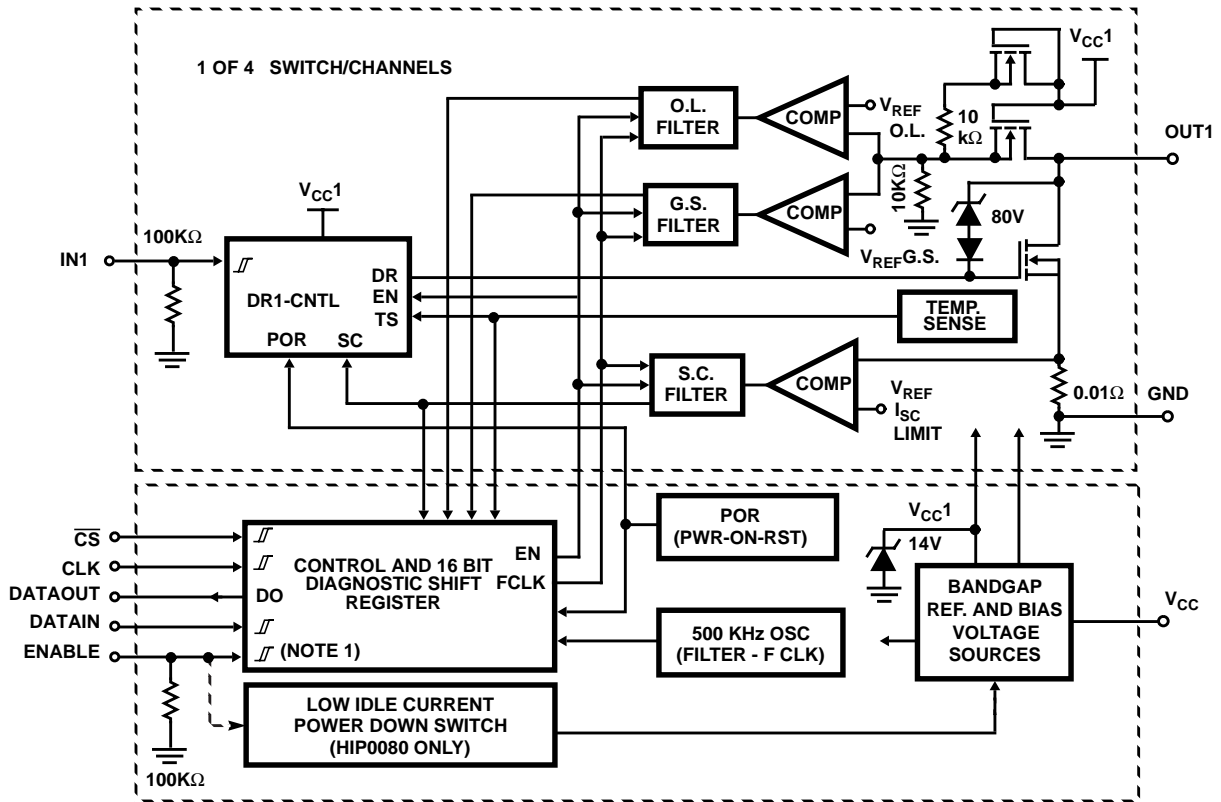

FIGURE 8. CA3282 TYPICAL APPLICATION CIRCUIT WITH SPI BUS CONTROL



NOTE:

1. HIP0080 - no enable hysteresis.

FIGURE 9. EQUIVALENT FUNCTION BLOCK DIAGRAM OF THE HIP0080 AND HIP0081

Application Note 9201

voltage clamp protection of each output. The circuit of Figure 8 illustrates an automotive application where a CDP68HC05 microprocessor or equivalent controls the SPI bus and determines what action if any will happen when a fault is detected. In this way the CA3282 is designed to support a variety of applications such as industrial controls. Due to the high cold starting current of lamp loads, it is not advisable to switch-on more than one lamp load at a time. Included in the many features of the CA3282 is a very low logic supply current to support the needs for low stand-by current drain.

HIP0080 and HIP0081 Quad Power MOSFET Drivers with Serial Diagnostic Interface

The HIP0080 and HIP0081 are low side power switches fabricated in a Power BiMOS process technology. They can typically sustain higher voltage and current capability than Power Bipolar ICs. Except for package and pinout differences, both circuits are functionally similar as shown in the functional block diagram of Figure 9. The HIP0080 and HIP0081 are designed to sustain 1A and 2A respectively of DC output current drive. The output drivers are voltage rated up to the clamp level set by drain-to-gate zener diodes and typically clamp at 80V for the HIP0081 and 36V for the HIP0080. A 15 pin SIP power package is used to achieve maximum capability for the HIP0081 while the HIP0080 is available in the 28 pin PLCC web lead frame package.

The diagnostic monitoring and feedback process of the HIP0080 and HIP0081 is different from the CA3282. Each output device is independently toggled on or off through a driver interface circuit that is, in part, controlled by over-current and over-temperature diagnostic feedback. The conditions on each output device are monitored to sense over-current, over-temperature, open-load and output-ground shorting. Four separate bits for each of the four outputs are loaded into a 16 bit serial diagnostic register. The diagnostic information is accessed with a low on the chip select pin and the clock input. Both DATA IN and DATA OUT pins are available to allow cascade operation. The first bit in the data readout is a fault error flag which is high if any one of the following 16 bits indicate a fault condition. When chips are cascaded, the error flags are cascaded and a fault condition is immediately evident if there is a fault on any chip. Although, all bits must be read to determine where, if any, the fault condition exists. While the diagnostic interface for data gathering purposes is quite different than the CA3282, the drive control and diagnostic feedback is SPI Bus compatible.

Another part of the diagnostic feedback circuits provides for digital delay filtering to prevent short transient over-current and output voltage readings from loading the diagnostic register with false data. Each output is sensed with a window comparator to determine whether the output is high, low or centered. A resistor divider consisting of two 10K Ω resistors sets a reference voltage level for the window comparator. When a centered reading is detected with the driver output off, the centered reading is sensed as a no load condition on the output. If the window comparator senses a low reading when the driver output is off, the result is interpreted as a short to ground.

The results are passed through a digital delay filter and are transmitted to the diagnostic shift register. The over-current sense level is read from a metal source-to-ground resistance in each output by a comparator that senses the voltage as a current. When an over-current level is detected, the result is sent through a digital delay filter to the diagnostic shift register and also toggles a latch circuit in the drive control which cuts-off drive to the output stage. Where a shorted condition exists, the short must be removed and the input toggled off and on to reset normal operation. If an over-temperature condition is sensed, the feedback result is fed directly back to the input control stage to gate-off drive to the output stage while also loading the diagnostic shift register. Normal chip operation may resume when the chip is sufficiently cooled. There is a typical 15 $^{\circ}$ C hysteresis shift intended by design to provide a cooling cutoff period.

Summary

While this information on the protective structures of the Quad & Octal Power Drivers should be helpful, it must also be recognized that the design of the application circuit should be consistent with performance requirements. Generally, the data sheets define parameters in terms of each separate switch. Although the data sheets do not specify parallel switch ratings and limits, the switches may be used in parallel to increase current drive capability. Also, there are a number of design considerations that will impact the continuing performance and reliability of the IC. The protective features of the Quad and Octal Drivers discussed here provide substantial system application protection by reducing the potential for catastrophic failure. To provide the user with a better in-sight into the device on-chip functions, the function block diagrams with their respective protection features have been included here. Additional detail can be found in the data sheet for each type.

References

1. CA3262, CA3272 distributed Automotive Brochures provided a document titled "Quad Power Drivers", No. BR-002. (Stress Data)
2. CA3262 - PCIM June 1988 article titled "Current and Temperature Limiting Protect Power Switch Driver Outputs" which has shutdown timing information to show the independent action of shutdown plus other application detail.

For reference, the data sheet file numbers are listed by type as follows:

TYPE	NO.	TYPE	NO.
CA3242	1561.2	CA3282	2767.4
CA3262, CA3262A	1836.3	CA3292A	2223.3
CA3272, CA3272A	2223.3	HIP0080, HIP0081	3018.2

Acknowledgments

The material presented here has been written by Wayne Austin, Intersil Intelligent Power Product Applications of the Intersil Automotive Design Center, Somerville, NJ with contributions from Tom DeShazo, Lou Pennisi, Bob Kumbatovic and Paul Dackow.

Application Note 9201

All Intersil semiconductor products are manufactured, assembled and tested under **ISO9000** quality systems certification.

Intersil products are sold by description only. Intersil Corporation reserves the right to make changes in circuit design and/or specifications at any time without notice. Accordingly, the reader is cautioned to verify that data sheets are current before placing orders. Information furnished by Intersil is believed to be accurate and reliable. However, no responsibility is assumed by Intersil or its subsidiaries for its use; nor for any infringements of patents or other rights of third parties which may result from its use. No license is granted by implication or otherwise under any patent or patent rights of Intersil or its subsidiaries.

For information regarding Intersil Corporation and its products, see web site <http://www.intersil.com>

Sales Office Headquarters

NORTH AMERICA

Intersil Corporation
P. O. Box 883, Mail Stop 53-204
Melbourne, FL 32902
TEL: (407) 724-7000
FAX: (407) 724-7240

EUROPE

Intersil SA
Mercure Center
100, Rue de la Fusee
1130 Brussels, Belgium
TEL: (32) 2.724.2111
FAX: (32) 2.724.22.05

ASIA

Intersil (Taiwan) Ltd.
Taiwan Limited
7F-6, No. 101 Fu Hsing North Road
Taipei, Taiwan
Republic of China
TEL: (886) 2 2716 9310
FAX: (886) 2 2715 3029